

V.12

Compact Full-Range System



Features

- Full-range, passive two-way system
- KTV specific voicing
- Enhanced bass response from rear port
- LF driver with demodulating ring for distortion-free vocals
- User-rotatable horn
- Vertical and horizontal mounting option
- Cloth-backed perforated steel grille
- Trapezoid enclosure with textured finish
- 8Ω nominal impedance
- Internal crossover network with LF and HF driver protection
- Twin NL4 connectors
- Multiple M8 rigging inserts

Applications

- Family and Premium KTV
- Music bars

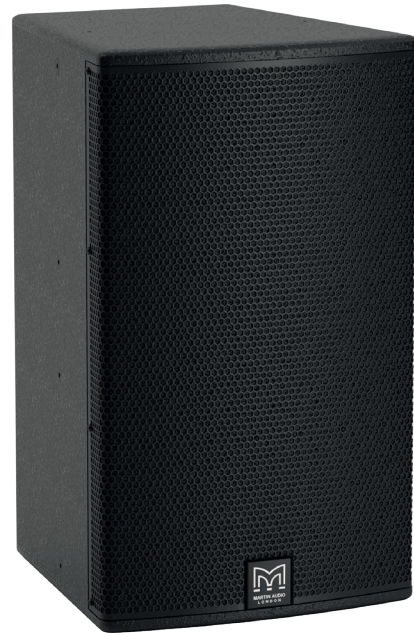

With the new V. Series, Martin Audio engineers have designed a range of premium full-range loudspeakers specifically for small-medium scale entertainment installations and family KTV. Three, passive two-way systems — the V.10, V.12 and V.15 — combine the Martin Audio signature sound of warmth, clarity and smooth response with the vocal presence required for a great Karaoke experience.

Each V. Series enclosure features a user-rotatable horn for vertical or horizontal orientation and multiple M8 threaded inserts for easy installation. The trapezoid enclosures are braced internally to reduce panel resonances and improve sonic performance and are finished in a textured black paint, with drivers protected by a perforated steel grille.

Rear ports couple the low-frequency output to walls or ceiling, producing enhanced bass output that can be felt without the need for additional subwoofers. This is particularly useful where space or budget may not allow for subwoofer support. In addition the LF drivers have demodulating rings providing clear, distortion-free vocal reproduction, even at high SPL. And because KTV loudspeakers can be used at high SPL's for many hours, internal crossover networks incorporate technology to protect the low and high frequency drivers and assure reliability without interrupting the performance.

Premium yet affordable, the V. Series takes the performance of compact entertainment loudspeakers to a new level and brings the celebrated signature sound of Martin Audio for KTV.

The V.12 is a high-performance, two-way entertainment system. With a maximum SPL of 130dB peak @ 1m, it is ideal for KTV rooms that require high sound levels and vocal clarity from a compact enclosure. It features a 12" (300mm)/2.5" (63mm) voice coil LF driver unit and a 1" (25mm) exit compression driver with a 1.4" (35mm) polyimide diaphragm on a rotatable 80° x 50° HF horn.

It produces impressive low frequency output from its optimised, compact, rear-ported trapezoid enclosure without the need for an additional subwoofer when mounted close to a wall or ceiling. The V.12's trapezoid enclosure is constructed from 15mm engineered wood fibre and fitted with multiple M8 inserts for eyebolt suspension and installation.

V.12

Compact Full-Range System



Technical Specifications

TYPE	Compact, passive two-way system
FREQUENCY RESPONSE (1)	62Hz-20kHz \pm 3dB -10dB @ 47Hz
DRIVERS	LF: 12" (300mm)/2.5" (63.5mm) voice coil, ferrite motor system HF: 1" (25mm) exit/1.4" (35mm) voice coil, polyimide dome compression driver
RATED POWER (2)	600W program, 1200W peak
RECOMMENDED AMP	VIA5002
SENSITIVITY (8)	99dB
MAXIMUM SPL (9)	127dB program, 130dB peak
NOMINAL IMPEDANCE	8 ohms
DISPERSION (-6dB)	80° H x 50° V (user-rotatable)
CROSSOVER	2.5kHz passive
ENCLOSURE	Trapezoid
FINISH	Black textured paint
PROTECTIVE GRILLE	Black perforated steel with scrim cloth backing
CONNECTORS	2 x NL4 type
PIN CONNECTIONS (INPUT)	1+/-
PIN CONNECTIONS (LINK)	1+/- to 1+/-
FITTINGS	14 x M8 inserts
DIMENSIONS	(W) 357mm x (H) 600mm x (D) 385mm (W) 14.1ins x (H) 23.6ins x (D) 15.2ins
WEIGHT	21kg (46.3lbs)

Notes

- (1) Measured on-axis in half (2pi) space at 2 metres, then referred to 1 metre.
- (2) AES Standard ANSI S4.26-1984.
- (3) Measured in half (2pi) space at 2 metres with 1 watt input, using band limited pink noise, then referred to 1 metre.
- (4) Measured in half (2pi) space at 2 metres using band limited pink noise, then referred to 1 metre.
- (5) Measured on-axis in open (4pi) space at 2 metres, then referred to 1 metre.
- (6) Measured in open (4pi) space at 2 metres with 1 watt input, using band limited pink noise, then referred to 1 metre.
- (7) Measured in open (4pi) space at 2 metres using band limited pink noise, then referred to 1 metre.
- (8) Measured in open (4pi) space at 2 metres with 2.83v input, using band limited pink noise, then referred to 1 metre.
- (9) Calculated at 1 metre.
- (10) Measured in half (2pi) space at 2 metres with 2.83V input, using band limited pink noise, then referred to 1 metre.

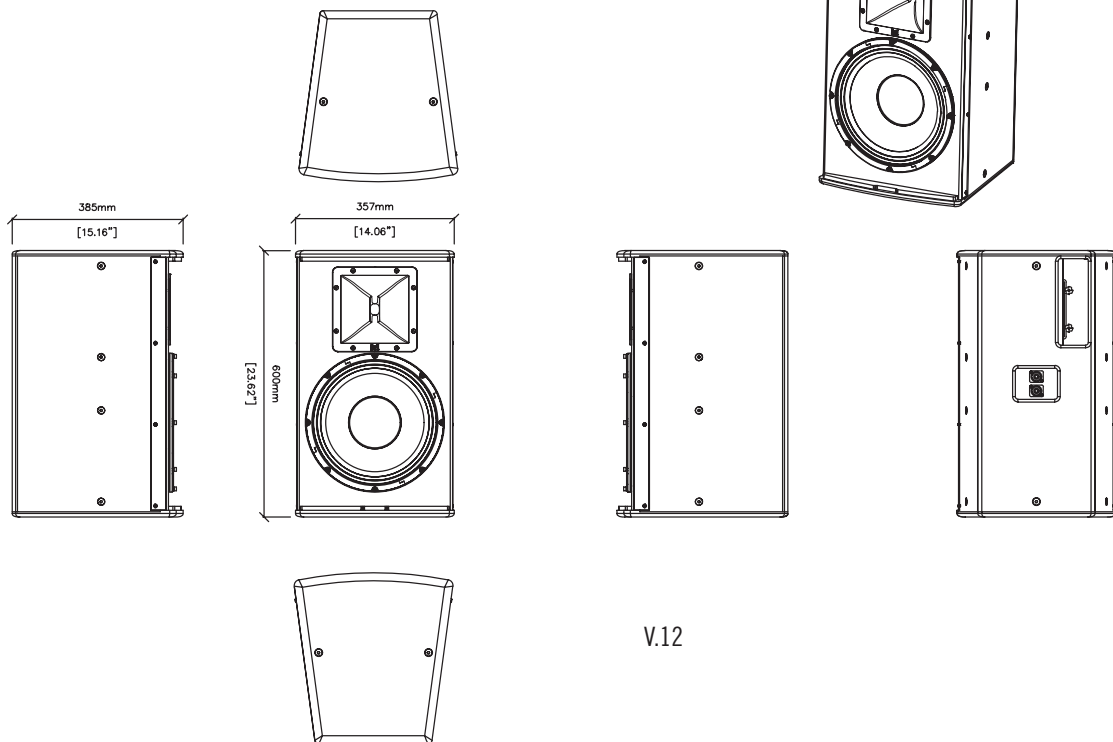

V.12

Martin Audio Ltd
Century Point, Halifax Road, High Wycombe
Buckinghamshire HP12 3SL, England

Telephone: +44 (0) 1494 535 312
Facsimile: +44 (0) 1494 438 669
Email: info@martin-audio.com

