

# CDD5TX-WR

Ultra-Compact Coaxial Differential Dispersion System  
with 70/100V Line Transformer - Weatherised



## Features

- Ultra-compact, CDD™ passive two-way system
- Coaxial Differential Dispersion™ technology
- Elegant ABS moulded enclosure
- Outdoor operation when sheltered from direct exposure to elements
- Operating temperature -20°C to +70°C
- Environmentally tested to meet IP54
- User-rotatable coaxial drive unit
- Vertical and horizontal mounting options
- Screw-free water and particle resistant grille
- 8Ω nominal impedance
- Discreet weatherised mounting accessories
- Black or white standard colour options
- 70V/100V line transformer
- Supplied with 'pan and tilt' weatherised mounting bracket



## Applications

- Bars and restaurants
- Museums and AV spaces
- Convention centres
- Hotels
- Retail outlets
- Leisure centres
- Houses of Worship
- Outdoor restaurants, bars, hotel areas
- Nearfield systems in outdoor stadia, transport hubs, concourses and theme parks

The CDD5TX-WR is a weatherised two-way passive micro speaker incorporating a 70V/100V line transformer and designed for discreet positioning in architectural installations — including bars, museums, foyers, concourses, exhibition centres and HoW as well as outdoor applications where it will be subject to changing environmental conditions, but sheltered from direct exposure to the elements. It features a unique, patent-pending 5" (125mm) LF/0.7" (19mm) HF Coaxial Differential Dispersion driver in a rigid ABS moulded enclosure with a dual cable gland for easy daisy-chaining of cabinets without the need for external breakout boxes and is supplied with a dedicated omni-directional mounting weather resistant bracket.

The Coaxial Differential Dispersion technology employed in the CDD5TX-WR delivers more consistent audience coverage than systems with fixed X° x Y° coverage patterns — projecting relatively more output to the rear of the audience to distribute sound evenly front-to-back, while having wide horizontal coverage close-up. Its innovative CDD driver achieves 'point source' summation of the LF and HF sections — eliminating off-axis variations in frequency response in the crossover region associated with non-coaxial designs. Improving on conventional coaxial designs, which can suffer from high-frequency beaming, the driver features a static waveguide that merges seamlessly with the unique cone shape — maintaining the dispersion

pattern out to very high frequencies.

The visually-distinctive enclosure can be used in either horizontal (landscape) or vertical (portrait) orientation, with rotation of the driver easily accomplished by removing the screw-free, protective grille. The curved shape of the enclosure allows it to be surface-mounted close to a wall or ceiling by means of the supplied omni-directional bracket or an optional close-mount ceiling bracket.

CDD5TX-WR features a water and particle resistant grille made from zinc plated mild steel with powder coated finish and is suitable for operating temperatures between -20°C to +70°C and environmentally tested to meet IP54. Finished in black (RAL9005) or white (RAL9016) as standard.

A full-range, passive two-way system, the CDD5TX-WR should be used with a compatible controller with appropriate limiter settings to provide system protection. The EQ and limiter functions of a controller such as the Martin Audio DX0.5 or DX4.0, or a Martin Audio amplifier with onboard DSP will maximise its capabilities. When used with a CSX subwoofer, crossover and EQ functions can either be performed by the DX0.5 and DX4.0 system controllers, or by an iKON amplifier.

# CDD5TX-WR



## Ultra-Compact Coaxial Differential Dispersion System with 70/100V Line Transformer - Weatherised

### Technical Specifications

#### Acoustical

TYPE	Ultra-compact, Coaxial Differential Dispersion passive two-way system
FREQUENCY RESPONSE (5)	100Hz-20kHz $\pm$ 3dB -10dB @ 70Hz
DRIVER	LF: 5.25" (130mm)/1.25" (32mm) voice coil, long excursion, ferrite motor system HF: 0.75" (19mm) voice coil, fabric dome with neodymium motor system
RATED POWER (2)	100W AES, 400W peak
TRANSFORMER SETTINGS	100V line: 6W, 12.5W, 25W 70V line: 3W, 6W, 12.5W, 25W
RECOMMENDED AMPLIFIER	iK81
SENSITIVITY (8)	90dB
MAXIMUM SPL (9)	110dB continuous, 116dB peak 3W = 95dB, 6W = 98dB, 12.5W = 101dB, 25W = 104dB
NOMINAL IMPEDANCE	8 ohms
DISPERSION (-6dB)	120°-90° horizontal, 80° vertical (user-rotatable)
CROSSOVER	2.5kHz passive
ENCLOSURE	3 litre, ABS
FINISH	Black or white as standard (RAL as cost option)
PROTECTIVE GRILLE	Zinc plated mild steel with powder coated finish and weatherised backing
ENVIRONMENTAL	Rated at IP54
CONNECTORS	Low profile 13A push-lock, weatherproof input panel cover with dual cable glands
PIN CONNECTIONS	Left to right: Input+, Input -, Link -, Link +
FITTINGS	6 x M5 inserts for wall/ceiling brackets
DIMENSIONS	(W) 160mm x (H) 230mm x (D) 149mm (W) 6.3ins x (H) 9.1 ins x (D) 5.9 ins
WEIGHT	3.4kg (7.5lbs)
ACCESSORIES	Included: Wall bracket black, Wall bracket white Optional: CDDCB5B ceiling bracket black CDDCB5W ceiling bracket white

#### Notes

- (1) Measured on-axis in half (2pi) space at 2 metres, then referred to 1 metre.
- (2) AES Standard ANSI S4.26-1984.
- (3) Measured in half (2pi) space at 2 metres with 1 watt input, using band limited pink noise, then referred to 1 metre.
- (4) Measured in half (2pi) space at 2 metres using band limited pink noise, then referred to 1 metre.
- (5) Measured on-axis in open (4pi) space at 2 metres, then referred to 1 metre.
- (6) Measured in open (4pi) space at 2 metres with 1 watt input, using band limited pink noise, then referred to 1 metre.
- (7) Measured in open (4pi) space at 2 metres using band limited pink noise, then referred to 1 metre.
- (8) Measured in open (4pi) space at 2 metres with 2.83V input, using band limited pink noise, then referred to 1 metre.
- (9) Calculated at 1 metre.
- (10) Measured in half (2pi) space at 2 metres with 2.83V input, using band limited pink noise, then referred to 1 metre.

#### Trade Descriptions Act

Due to Martin Audio's policy of continuing improvement, we reserve the right to alter these specifications without prior notice. Martin Audio is committed to refining state of the art sound reinforcement, combining in-depth product and field applications research with advanced manufacturing techniques. Every Martin Audio product is built to the highest manufacturing standards and rigorously tested to ensure that it meets the performance criteria specified in the design.

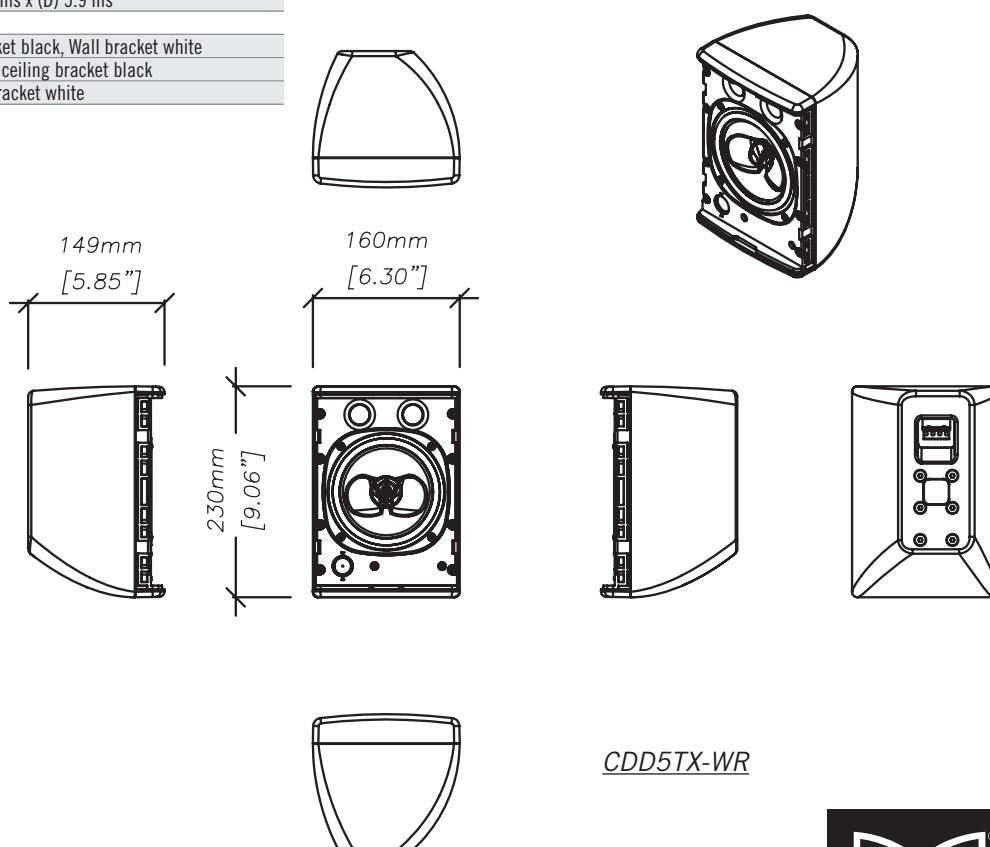

*CDD5TX-WR*