

# CDD8

## Ultra-Compact Coaxial Differential Dispersion System

### Features

- Ultra-compact, CDD<sup>™</sup> passive two-way system
- Coaxial Differential Dispersion<sup>™</sup> technology
- Elegant UPM Formi composite enclosure
- User-rotatable coaxial drive unit
- Vertical and horizontal mounting options
- Screw-free perforated steel grille
- 8Ω nominal impedance
- Discreet mounting accessories
- Black or white standard colour options

### Applications

- Live music clubs and bars
- Nightclubs
- Bars and restaurants
- Museums and AV spaces
- Convention centres
- Hotels
- Retail outlets
- Leisure centres
- Houses of Worship

The CDD8 is an ultra-compact two-way passive loudspeaker system with an integrated 8" (200mm) LF/1" (25mm) exit HF Coaxial Differential Dispersion driver which can be easily rotated for horizontal or vertical orientation depending on venue design requirements. Its small size gives no indication of its high output capability. As a stand-alone loudspeaker, it has a multitude of applications and can also be incorporated as an infill loudspeaker in distributed systems using larger CDD models, such as the CDD12 and CDD15.

The Coaxial Differential Dispersion technology employed in the CDD8 delivers more consistent audience coverage than systems with fixed X° x Y° coverage patterns — projecting relatively more output to the rear of the audience, while having wide horizontal coverage close-up. Its innovative CDD driver achieves 'point source' summation of the LF and HF sections — eliminating off-axis variations in frequency response associated with non-coaxial designs. Improving on conventional coaxial designs, which can suffer from high-frequency beaming, the driver features a static waveguide that merges seamlessly with the unique cone shape — maintaining the dispersion pattern out to very high frequencies.



The visually-distinctive enclosure can be used in either horizontal (landscape) or vertical (portrait) orientation, with rotation of the driver easily accomplished by removing the screw-free, protective grille. The curved shape of the enclosure allows it to be surface-mounted close to a wall or ceiling by means of optional wall and ceiling brackets.

Finished in black (RAL9005) or white (RAL9016) as standard, the CDD8 can be supplied in any RAL colour to order.

A full-range, passive two-way system, the CDD8 should be used with a compatible controller with appropriate limiter settings to provide system protection. The EQ and limiter functions of a controller such as the Martin Audio DX0.5 or DX4.0, or a Martin Audio amplifier with onboard DSP will maximise its capabilities. When used with a CSX subwoofer, crossover and EQ functions can either be performed by the DX0.5 and DX4.0 system controllers, or by an iKON amplifier.

# CDD8

## Ultra-Compact Coaxial Differential Dispersion System



### Technical Specifications

#### Acoustical

TYPE	Ultra-compact, Coaxial Differential Dispersion passive two-way system
FREQUENCY RESPONSE (5)	70Hz-20kHz $\pm$ 3dB, -10dB @ 55Hz
DRIVER	LF: 8" (200mm)/2" (50mm) voice coil, long excursion, shared ferrite motor system with HF HF: 1" (25mm) exit/1.4" (38mm) voice coil, polyimide dome compression driver
RATED POWER (2)	200W AES, 800W peak
RECOMMENDED AMPLIFIER	iK81 / VIA2502/2004
SENSITIVITY (8)	94dB
MAXIMUM SPL (9)	117dB continuous, 123dB peak
NOMINAL IMPEDANCE	8 ohms
DISPERSION (-6dB)	110°-80° horizontal, 60° vertical (user-rotatable)
CROSSOVER	2.3kHz passive
ENCLOSURE	14 litre, composite material
FINISH	Black or white textured paint
PROTECTIVE GRILLE	Black or white perforated steel with scrim cloth backing
CONNECTORS	Low profile 13A push-lock
PIN CONNECTIONS	Left to right: Input+, Input -, Link -, Link +
FITTINGS	6 x M6 inserts for wall/ceiling brackets
DIMENSIONS	(W) 256mm x (H) 410mm x (D) 252mm (W) 10.1ins x (H) 16.1ins x (D) 9.9ins
WEIGHT	9.5kg (21lbs)
ACCESSORIES	CDDWB6/8B wall bracket black CDDWB6/8W wall bracket white CDDCB6/8B ceiling bracket black CDDCB6/8W ceiling bracket white

#### Notes

- (1) Measured on-axis in half (2pi) space at 2 metres, then referred to 1 metre.
- (2) AES Standard ANSI S4.26-1984.
- (3) Measured in half (2pi) space at 2 metres with 1 watt input, using band limited pink noise, then referred to 1 metre.
- (4) Measured in half (2pi) space at 2 metres using band limited pink noise, then referred to 1 metre.
- (5) Measured on-axis in open (4pi) space at 2 metres, then referred to 1 metre.
- (6) Measured in open (4pi) space at 2 metres with 1 watt input, using band limited pink noise, then referred to 1 metre.
- (7) Measured in open (4pi) space at 2 metres using band limited pink noise, then referred to 1 metre.
- (8) Measured in open (4pi) space at 2 metres with 2.83V input, using band limited pink noise, then referred to 1 metre.
- (9) Calculated at 1 metre.
- (10) Measured in half (2pi) space at 2 metres with 2.83V input, using band limited pink noise, then referred to 1 metre.

#### Trade Descriptions Act

Due to Martin Audio's policy of continuing improvement, we reserve the right to alter these specifications without prior notice. Martin Audio is committed to refining state of the art sound reinforcement, combining in-depth product and field applications research with advanced manufacturing techniques. Every Martin Audio product is built to the highest manufacturing standards and rigorously tested to ensure that it meets the performance criteria specified in the design.

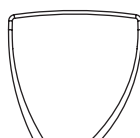
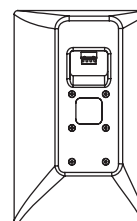
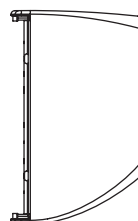
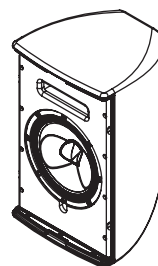
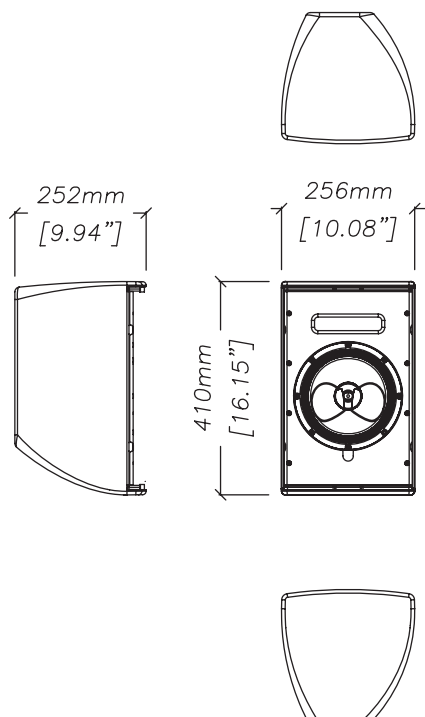

All information is Copyright © 2014 Martin Audio Ltd.

CDD8

Martin Audio Ltd  
Century Point, Halifax Road, High Wycombe  
Buckinghamshire HP12 3SL, England

Telephone: +44 (0) 1494 535 312  
Email: [info@martin-audio.com](mailto:info@martin-audio.com)

All information is Copyright © 2018 Martin Audio Ltd.



[www.martin-audio.com](http://www.martin-audio.com)