

# XD12

Compact high-output two-way system

## features

- ▶ Versatile high-output two-way system
- ▶ Compact, multi-angle plywood enclosure
- ▶ 12" (300mm)/3" (75mm) coil, long-excursion, low-distortion neodymium LF driver
- ▶ 1" (25mm) exit, Polyimide dome, neodymium HF compression driver
- ▶ User rotatable 80° x 50° horn
- ▶ Switchable passive/bi-amp crossover
- ▶ 8 ohm nominal impedance
- ▶ Integral pole-mount and M8 rigging inserts
- ▶ Comprehensive mounting options and accessories
- ▶ Five year limited warranty

## applications

- ▶ Portable live sound reinforcement
- ▶ Theatre Sound
- ▶ Fixed Installations
- ▶ High power stage monitor
- ▶ AV Presentations

The XD12 is a high-power, high-output, two-way system equally suited to portable live sound applications, theatre and fixed installations. It features a high-specification 12" (300mm) low frequency drive unit and a 1" (25mm) exit compression driver mounted on a user-rotatable 80° x 50° constant directivity horn.

The 12" (300mm) LF driver has a lightweight 3" (75mm) voice coil and flux demodulation rings to reduce distortion at high excursions. Its neodymium motor system combines high sensitivity with low weight and advanced cooling reduces power compression to negligible levels. The 1" (25mm) exit HF driver has a 1.7" (44mm) polyimide dome and ultra-high flux neodymium motor system for maximum efficiency, plus a copper cap to extend the HF response.

The internal HF/LF crossover is switchable between passive or bi-amp operation, depending on user requirements.



The XD12 is the perfect solution for high-power applications where flexibility, ease of installation and speed of deployment are important factors. The versatile, multi-angle enclosure and rotatable horn facilitate either horizontal or vertical orientation, and comprehensive brackets support the full variety of mounting options – including surface, ceiling and pole mount. Integral M8 inserts for simple eyebolt suspension increase the options even further. In its horizontal configuration, the XD12 is also ideal as a compact, high-output stage monitor.

When used in bi-amp mode, or with a subwoofer such as the Wavefront WS18X or WS218X, it is recommended that the XD12 is used with the Martin Audio DX0.5 or DX4.0 controller. When operated as a passive system, it may be used without a controller, but will benefit from the DX0.5 or DX4.0's EQ and limiter functions.

Century Point, Halifax Road, Cressex Business Park,  
High Wycombe, Buckinghamshire HP12 3SL, England.  
E-mail: [info@martin-audio.com](mailto:info@martin-audio.com)  
Telephone: +44 (0)1494 535312 Facsimile: +44 (0)1494 438669  
All information is Copyright © 2012 Martin Audio Ltd.



[www.martin-audio.com](http://www.martin-audio.com)

XD Series

# XD12

Compact high-output two-way system

XD Series

## overall dimensions

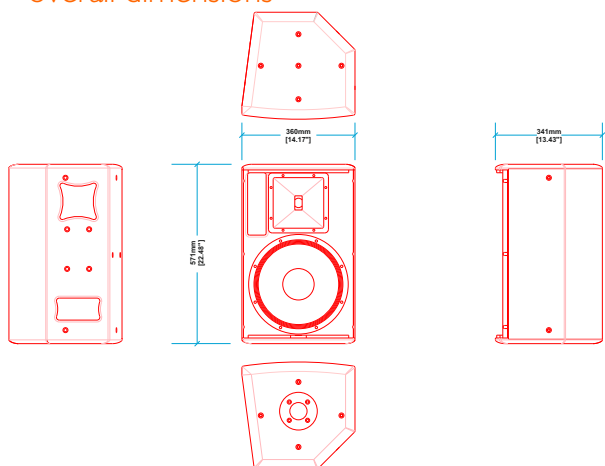

XD12

All information is Copyright © 2012 Martin Audio Ltd.

## accessories



XD12 Universal bracket (Trigger clamp not included)

## technical specifications

TYPE	Compact, high-output, passive/bi-amp two-way system
FREQUENCY RESPONSE (a)	65Hz-20kHz $\pm 3$ dB -10dB @ 55Hz
DRIVERS	12" (300mm)/3" (75mm) voice coil, long-excursion, neodymium magnet LF driver 1" (25mm) exit/1.7" (44mm) voice coil, titanium dome, neodymium magnet HF compression driver
RATED POWER (b)	LF: 400W AES, 1600W peak HF: 50W AES, 200W peak
RECOMMENDED AMPLIFIER	iK81 / VIA2502/5002/5004
SENSITIVITY (c)	FR: 98dB LF: 99dB HF: 108dB
MAXIMUM SPL (d)	FR: 124dB continuous, 130dB peak LF: 125dB continuous, 131dB peak HF: 122dB continuous, 131dB peak
NOMINAL IMPEDANCE	FR/LF: 8 ohms HF: 16 ohms
DISPERSION (-6dB)	80° horizontal, 50° vertical user rotatable
CROSSOVER	2kHz switchable passive/bi-amp
ENCLOSURE	38 litre, multi-laminate birch ply
FINISH	Textured black polyurea coating
PROTECTIVE GRILLE	Black perforated steel, Declon® backed
CONNECTORS	2 x Neutrik® NL4
INPUT CONNECTIONS	FR/LF (+,-): 1+, 1- HF (+,-): 2+, 2-
FITTINGS	21 x M8 threaded inserts, 1 x Pole mounting socket 1 x Pocket Handle
DIMENSIONS	(W) 360mm x (H) 571mm x (D) 341mm (W) 14.2ins x (H) 22.5ins x (D) 13.4ins
WEIGHT	19.5Kg (43lbs)

### Notes

- (a) measured on-axis in open ( $4\pi$ ) half space at 2 metres, then referred to 1 metre
- (b) AES Standard ANSI S4.26-1984
- (c) Measured in open ( $4\pi$ ) space at 2 metres with 1 watt input, using band limited pink noise, then referred to 1 metre
- (d) Measured in open ( $4\pi$ ) space at 2 metres using band limited pink noise, then referred to 1 metre

A universal bracket is available for the XD12 which offers a very versatile solution for mounting the cabinet. The bracket may be mounted in either the top or the bottom of the enclosure. The bracket gives quick and easy vertical angle adjustment with a spring loaded locking pin.

When mounted on the top the bracket offers a single point fixing which can either be a permanent bolt to a structure or a scaffold clamp such as the trigger clamp as shown in the picture (not supplied) which makes for very quick deployment from truss structures in a variety of applications from theatre productions to corporate AV.

When mounted on the bottom of the cabinet the single point fixing can be used in conjunction with a pole mount adaptor (part number HAM02041) as an alternative to the built in top hat fitting so that upwards or downwards tilt adjustment is available when the cabinet is used on a standard 35mm speaker stand

Century Point, Halifax Road, Cressex Business Park,  
High Wycombe, Buckinghamshire HP12 3SL, England.  
E-mail: info@martin-audio.com  
Telephone: +44 (0)1494 535312 Facsimile: +44 (0)1494 438669  
All information is Copyright © 2012 Martin Audio Ltd.



www.martin-audio.com