

# SX118

Compact, direct radiating subwoofer

## Features

- Compact, direct radiating subwoofer
- 18" (460mm)/4" (100mm) voice coil, long excursion, ferrite magnet, waterproof cone
- High output capability
- Tour-grade plywood enclosure with flying inserts

## Applications

- Touring sound reinforcement for small and medium-size venues
- Fixed installations in concert halls, theatres, ballrooms and HoW
- Sports stadium, arena installations & corporate AV events
- Outdoor restaurant, bar and hotel entertainment areas
- Concourses and Theme Parks



The SX118 is a compact, high performance subwoofer that extends the low frequency operating range of the system to 47Hz and provides exceptional low frequency output for such a compact enclosure. Please note this product has been updated since January 2019 from an earlier iteration.

SX118 features a long-excursion 18" (460mm)/4" (100 mm) voice coil driver with a water-resistant cone and triple roll surround in a compact reflex enclosure.

The design of the 18" driver maximises output while minimising power compression and distortion, and the four reflex ports have a large frontal area to reduce turbulent air noise at very high

levels. The enclosure is constructed from multi-laminate birch ply, finished with a durable polyurea coating and equipped with a Zintec grille, twin grab handles, skids, flying inserts for installation and a threaded pole socket for pole-mounting point source loudspeakers or up to 4 WPM enclosures as a simple plug-and-play system.

The product is supplied as standard without cabinet wheels, but they are available as an accessory.

By adding the input board cover accessory, SX118 is fully weather resistant and suitable for permanent outdoor usage.

# SX118

## Compact, direct radiating subwoofer

### Technical Specifications

TYPE	Compact, direct radiating subwoofer
FREQUENCY RESPONSE (1)	47Hz – 150Hz ±3dB, -10dB @ 41Hz
DRIVER	18" (460mm)/4" (100mm) voice coil, long excursion, ferrite magnet, waterproof cone
RATED POWER (2)	1000W AES, 4000W peak
SYSTEM AMPLIFIER	iKON iK42, iK81
SENSITIVITY (10)	102dB
MAXIMUM SPL(9)	138dB peak
NOMINAL IMPEDANCE	8 ohms
DISPERSION (-6dB)	Omnidirectional/or Cardioid (paired)
ENCLOSURE	Multi-laminate birch/poplar ply
FINISH	Textured black paint
PROTECTIVE GRILLE	Black perforated Zintec
CONNECTORS	2 x NL4
PIN CONNECTIONS (INPUT)	LF: +1, -1 Link through: +2, -2
PINS CONNECTIONS (LINK)	LF: +1, -1 Link through: +2, -2
FITTINGS	Two skids on base, with mating channels on top M20 top-mounted thread plate for pole mounting 16 x M10 mounting points 2 x bar handles, 1 on each side 4 x fittings for optional transit cover 16 x M8 inserts for optional castors
DIMENSIONS (INCL SKIDS)	(W) 600mm x (H) 509mm x (D) 632mm (760mm incl. castors) (W) 24in x (H) 20.36in x (D) 25.26in (30.38in incl. castors)
WEIGHT	43.5kg(96lbs) w/o castors, 47kg(104lbs) with castors
ACCESSORIES	16 x M8 inserts for optional castors, Input Board Cover, Transit Cover

#### Notes

- (1) Measured on-axis in half (2pi) space at 2 metres, then referred to 1 metre.
- (2) AES Standard ANSI S4.26-1984.
- (3) Measured in half (2pi) space at 2 metres with 1 watt input, using band limited pink noise, then referred to 1 metre.
- (4) Measured in half (2pi) space at 2 metres using band limited pink noise, then referred to 1 metre.
- (5) Measured on-axis in open (4pi) space at 2 metres, then referred to 1 metre.
- (6) Measured in open (4pi) space at 2 metres with 1 watt input, using band limited pink noise, then referred to 1 metre.
- (7) Measured in open (4pi) space at 2 metres using band limited pink noise, then referred to 1 metre.
- (8) Measured in open (4pi) space at 2 metres with 2.83v input, using band limited pink noise, then referred to 1 metre.
- (9) Calculated at 1 metre.
- (10) Measured in half (2pi) space at 2 metres with 2.83V input, using band limited pink noise, then referred to 1 metre.

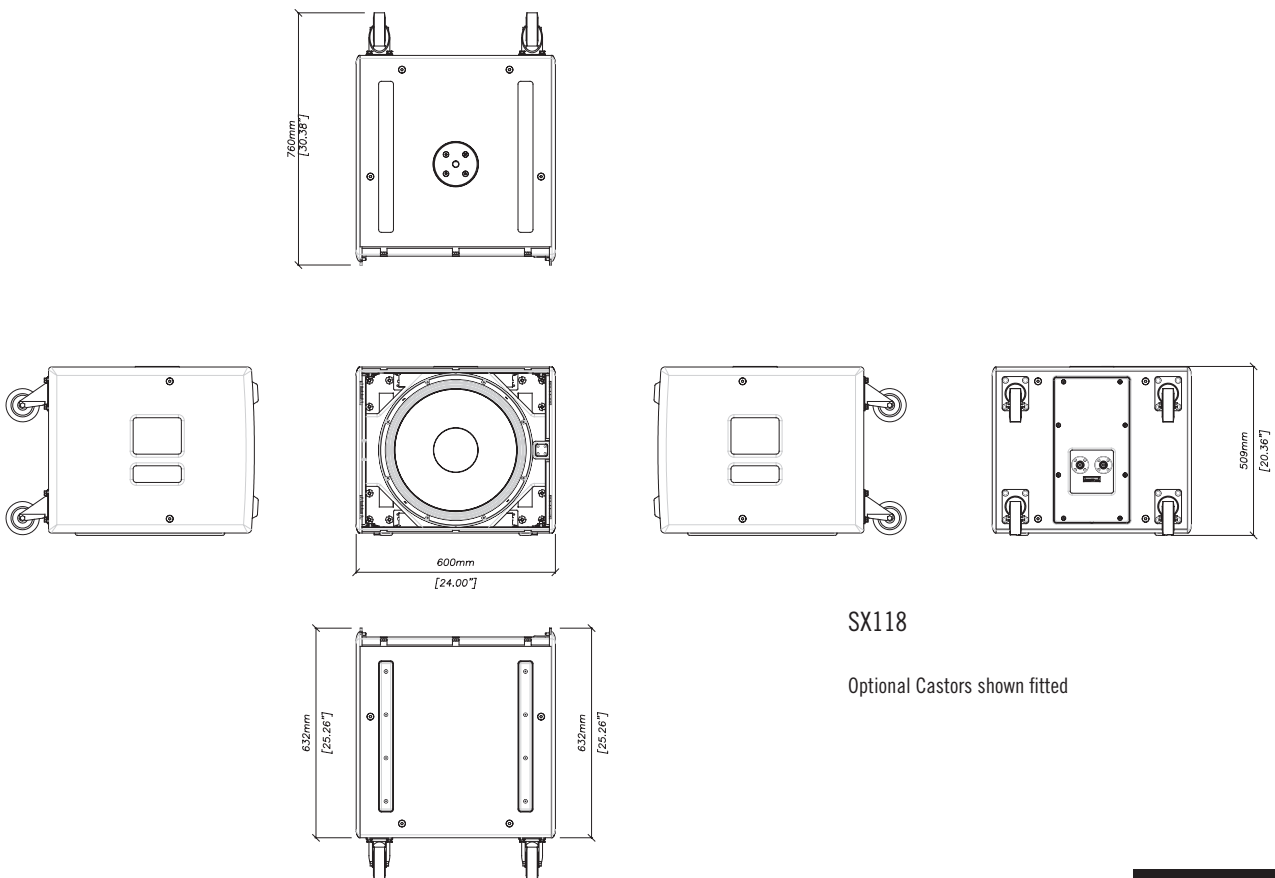

SX118

Optional Castors shown fitted

# SX118

Compact, direct radiating subwoofer

## System Amplifier Technical Specifications

### iK42 Amplifier

General	
TYPE	Four-channel Class D amplifier
POWER OUTPUT	4 x 5000W into 2 ohms, all channels driven 4 x 3000W into 4 ohms, all channels driven 4 x 1500W into 8 ohms, all channels driven
DIGITAL SIGNAL PROCESSING	96kHz DSP on all inputs and outputs
COOLING	Dual vari-speed fans, front-to-back airflow
MAXIMUM AMBIENT TEMPERATURE	40°C (104°F)
Audio Inputs/Outputs	
ANALOGUE IN/LINK (4 CHANNELS)	4 x female, 4 x male Neutrik™ XLR
ANALOGUE INPUT IMPEDANCE	20kΩ balanced to ground
MAXIMUM ANALOGUE INPUT LEVEL	+20dBu
NOMINAL SYSTEM GAIN	32dB
AES3 IN/LINK (2 CHANNELS)	1 x female, 1 x male Neutrik™ XLR, balanced
DANTE™ (4 CHANNELS)	2 x shielded RJ45, primary and secondary
AMPLIFIER OUTPUTS	4 x Neutrik Speakon™ NL4
Control and Monitoring Network	
PROTOCOL	Ethernet
CONTROL APPLICATION	Martin Audio VU-NET™
Power Supply	
TYPE	High performance Series Resonant
AC INPUT OPERATING RANGE	85 – 240V ~ AC, 47 - 63Hz
MAINS INRUSH CURRENT	6A at 115V, 12A at 230V (max for <10ms)
MAINS CONNECTOR	Neutrik 32A Powercon™
Physical	
DIMENSIONS	(W) 482 x (H) 2U/88mm x (D) 441mm (W) 18.98in x (H) 2U/3.46in x (D) 17.35in incl handles and optional rear support
WEIGHT	12.5kg (27.5lbs)

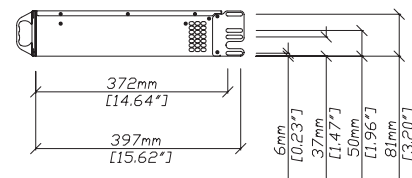
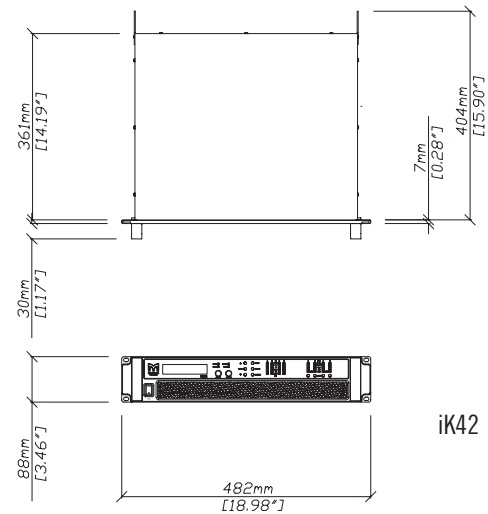

### iK81 Amplifier

General	
TYPE	Eight-channel Class D amplifier
POWER OUTPUT	8 x 1250W into 2 ohms, all channels driven 8 x 1250W into 4 ohms, all channels driven 8 x 1250W into 8 ohms, all channels driven
DIGITAL SIGNAL PROCESSING	96kHz DSP on all inputs and outputs
COOLING	Dual vari-speed fans, front-to-back airflow
MAXIMUM AMBIENT TEMPERATURE	40°C (104°F)
Audio Inputs/Outputs	
ANALOGUE IN/LINK (4 CHANNELS)	4 x female, 4 x male Neutrik™ XLR
ANALOGUE INPUT IMPEDANCE	20kΩ balanced to ground
MAXIMUM ANALOGUE INPUT LEVEL	+20dBu
NOMINAL SYSTEM GAIN	32dB
AES3 IN/LINK (2 CHANNELS)	1 x female, 1 x male Neutrik™ XLR, balanced
DANTE™ (4 CHANNELS)	2 x shielded RJ45, primary and secondary
AMPLIFIER OUTPUTS	4 x Neutrik Speakon™ NL4
Control and Monitoring Network	
TOPOLOGY	Ethernet
CONTROL APPLICATION	Martin Audio VU-NET™
Power Supply	
TYPE	High performance Series Resonant
AC INPUT OPERATING RANGE	85 – 240V ~ AC, 47 - 63Hz
MAINS INRUSH CURRENT	6A at 115V, 12A at 230V (max for <10ms)
MAINS CONNECTOR	Neutrik 32A Powercon™
Physical	
DIMENSIONS	(W) 482 x (H) 2U/88mm x (D) 441mm (W) 18.98in x (H) 2U/3.46in x (D) 17.35in incl handles and optional rear support
WEIGHT	12.5kg (27.5lbs)

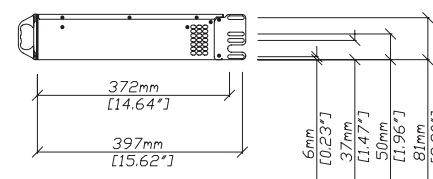
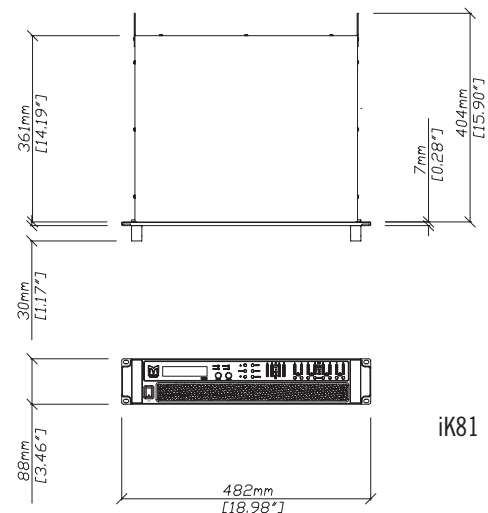

#### Trade Descriptions Act

Due to Martin Audio's policy of continuing improvement, we reserve the right to alter these specifications without prior notice. Martin Audio is committed to refining state of the art sound reinforcement, combining in-depth product and field applications research with advanced manufacturing techniques. Every Martin Audio product is built to the highest manufacturing standards and rigorously tested to ensure that it meets the performance criteria specified in the design.

Martin Audio Ltd

Century Point, Halifax Road, High Wycombe  
Buckinghamshire HP12 3SL, England

Telephone: +44 (0) 1494 535 312  
Email: [info@martin-audio.com](mailto:info@martin-audio.com)

All information is Copyright © 2020 Martin Audio Ltd.



[www.martin-audio.com](http://www.martin-audio.com)